

**Rebel Crank-Up 1000
User Manual For Wood And Glass Tops**

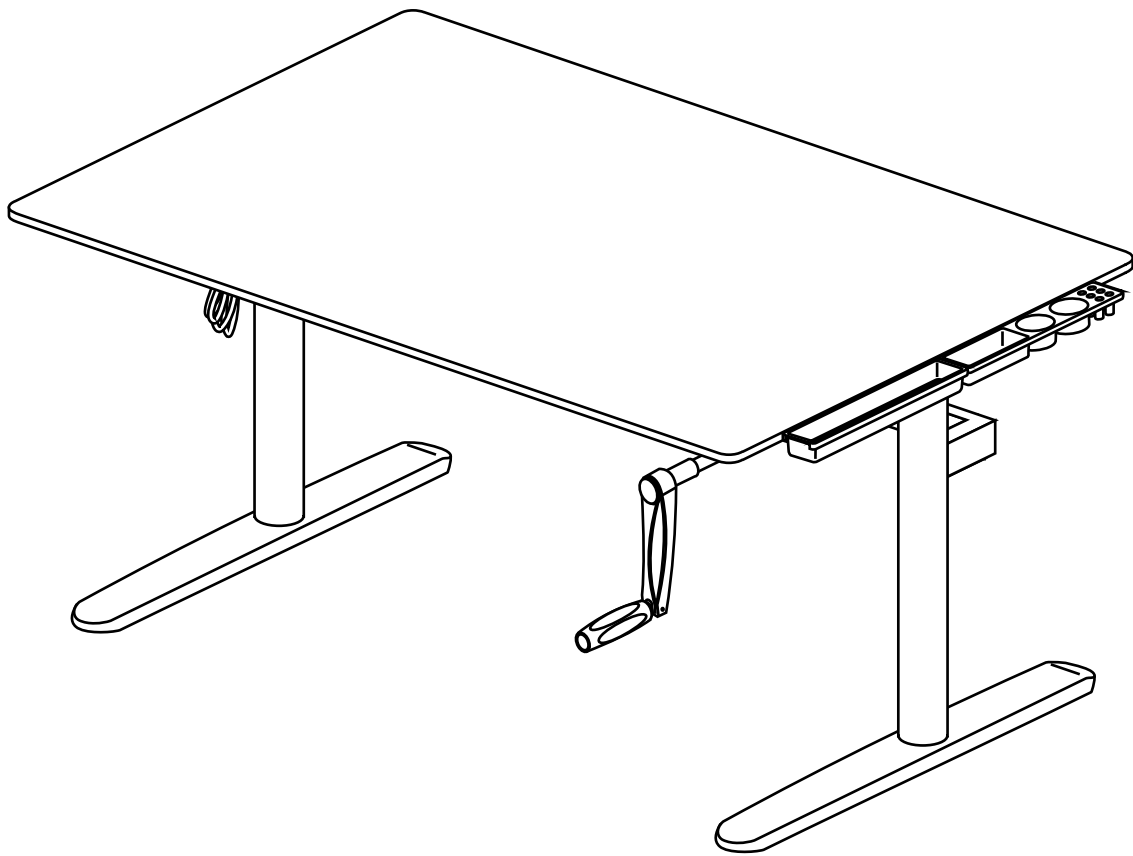

REBELDESK

Congratulations! You are about to join the rebellion. The rebellion against the sitting culture.

Between computers, cars, and television, we are sitting more than ever – on average more than nine hours a day. All this time on our rear ends has terrible effects on, well, our rear ends, and also our energy levels, ability to concentrate, and long-term health.

But you are taking a stand against the sitting culture with your Rebel Crank-Up 1000. By standing while you work, you can keep the negative effects of sitting at bay. Plus you can be more focused, alert, and energized throughout the day.

Before you begin using your Rebel Crank-Up 1000, please read the entire manual.

If you have any questions, concerns, or just want someone to celebrate with, give us a call at 1-855-REBEL UP or send us a message at info@rebeldesk.com



IMPORTANT SAFETY INSTRUCTIONS

WARNING!







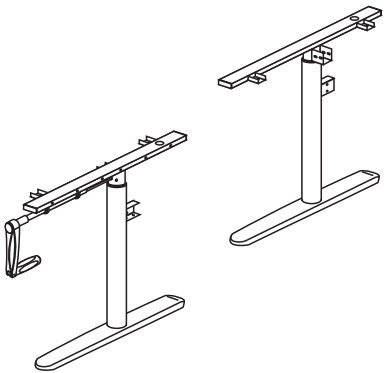
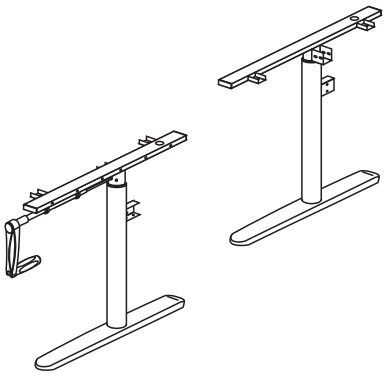

Failure to comply with the assembly, safety, and operating instructions for the Rebel Crank-Up 1000 could result in serious bodily injury.

SAFETY INSTRUCTIONS





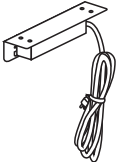

- Read the entire manual before attempting to assemble or use the Rebel Crank-Up 1000.
- Use caution when lifting the desk components. Obtain assistance if needed.
- Use two people for assembly.
- Make sure that the floor on which you intend to use the Rebel Crank-Up 1000 is level.
- The Rebel Crank-Up 1000 is not intended for use by children.
- Ensure that all those who use the Rebel Crank-Up 1000 are familiar with the operating instructions.
- Never stand or sit on the desktop.

Included with the desk are all of the parts needed to assemble the base and attach both the wood top and the glass top. Regardless of what top you put on the desk base, you will have extra parts after assembly is complete.





PARTS LIST FOR THE DESK BASE CONTENT

NUMBER/ DESCRIPTION	QUANTITY	IMAGE
1. Left Leg	1	
2. Right Leg	1	
3. Front Support Bar	1	
4. Rear Support Bar	1	
5. Center Support Bar	1	
6. Rear Bar	1	
7. Connector	1	
8. Charging Station	1	
9. Cable Collar	2	

PARTS LIST FOR THE DESK BASE CONTENT

NUMBER/ DESCRIPTION	QUANTITY	IMAGE
10. Partitioned Organizer Tray	1	
11. Organizer Tray	1	
12. Short Allen Bolt	24	
13. Phillips Bolt	4	
14. Phillips Screw	2	
15. Allen Wrench	1	

PARTS LIST FOR WOOD TOP

14. Phillips Screw	4	
16. Plastic Bracket	4	
17. Washer	4	
18. Long Allen Bolt	4	

PARTS LIST FOR GLASS TOP

12. Short Allen Bolt	10	
19. Support Tray	2	

IF PURCHASED :

WOOD TOP PACKED IN A SEPARATE BOX

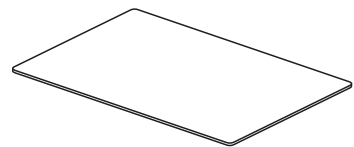

GLASS TOP PACKED IN A SEPARATE BOX

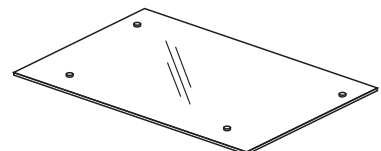

Assembly Of The Desk Base - STEP 1

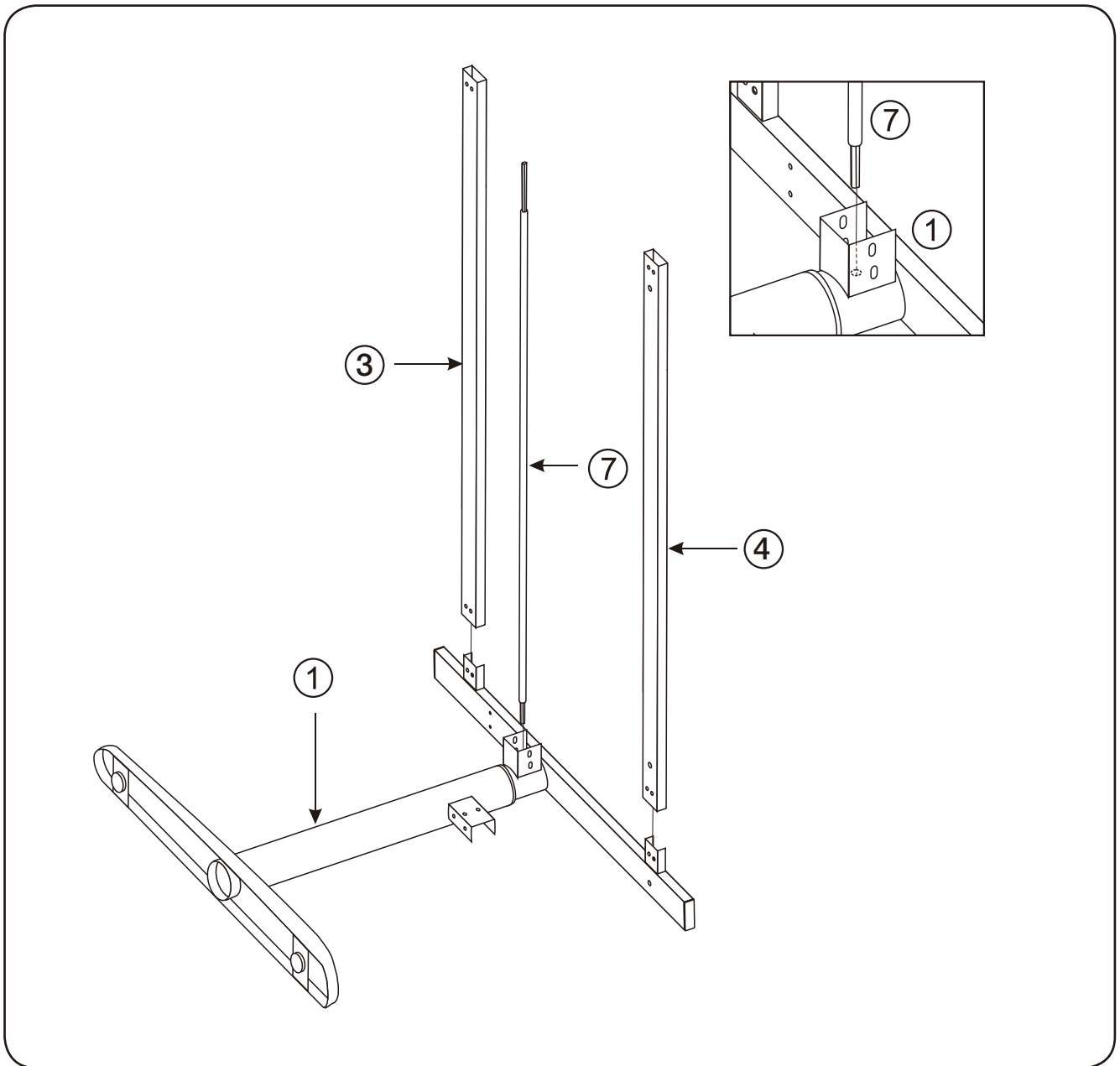

- Use two people for the assembly.
- Lay the Left Leg (1) down on floor. Place the Front Support Bar (3) and the Rear Support Bar (4) on the Left Leg and insert the Connector (7) into the Left Leg (1).

Assembly Of The Desk Base - STEP 2

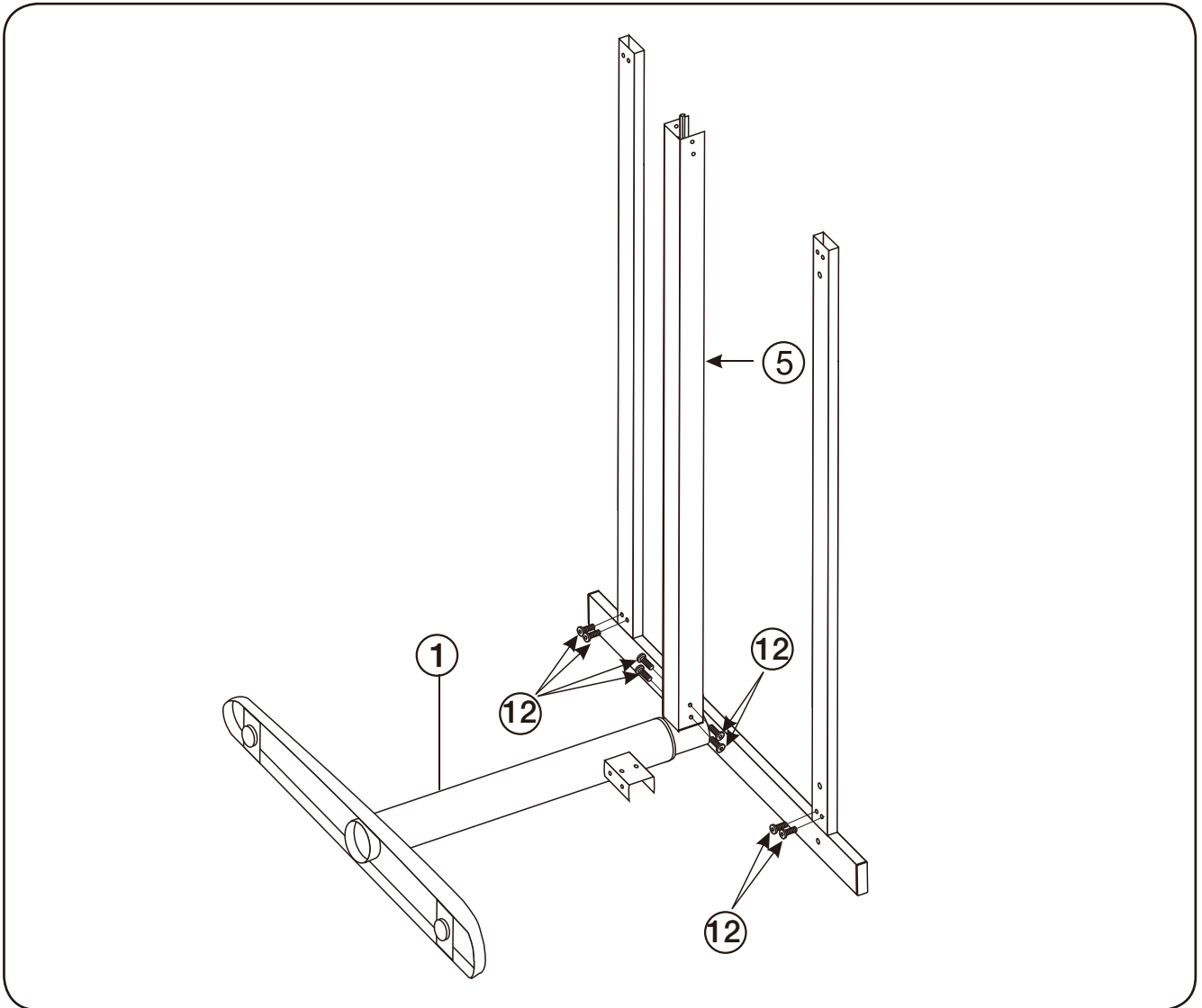

- Place the Center Support Bar (5) on the Left Leg (1).
- Attach all Support Bars to the Left Leg (1) using the Short Allen Bolts (12). Allow the screws to remain slightly loose.

Assembly Of The Desk Base - STEP 3

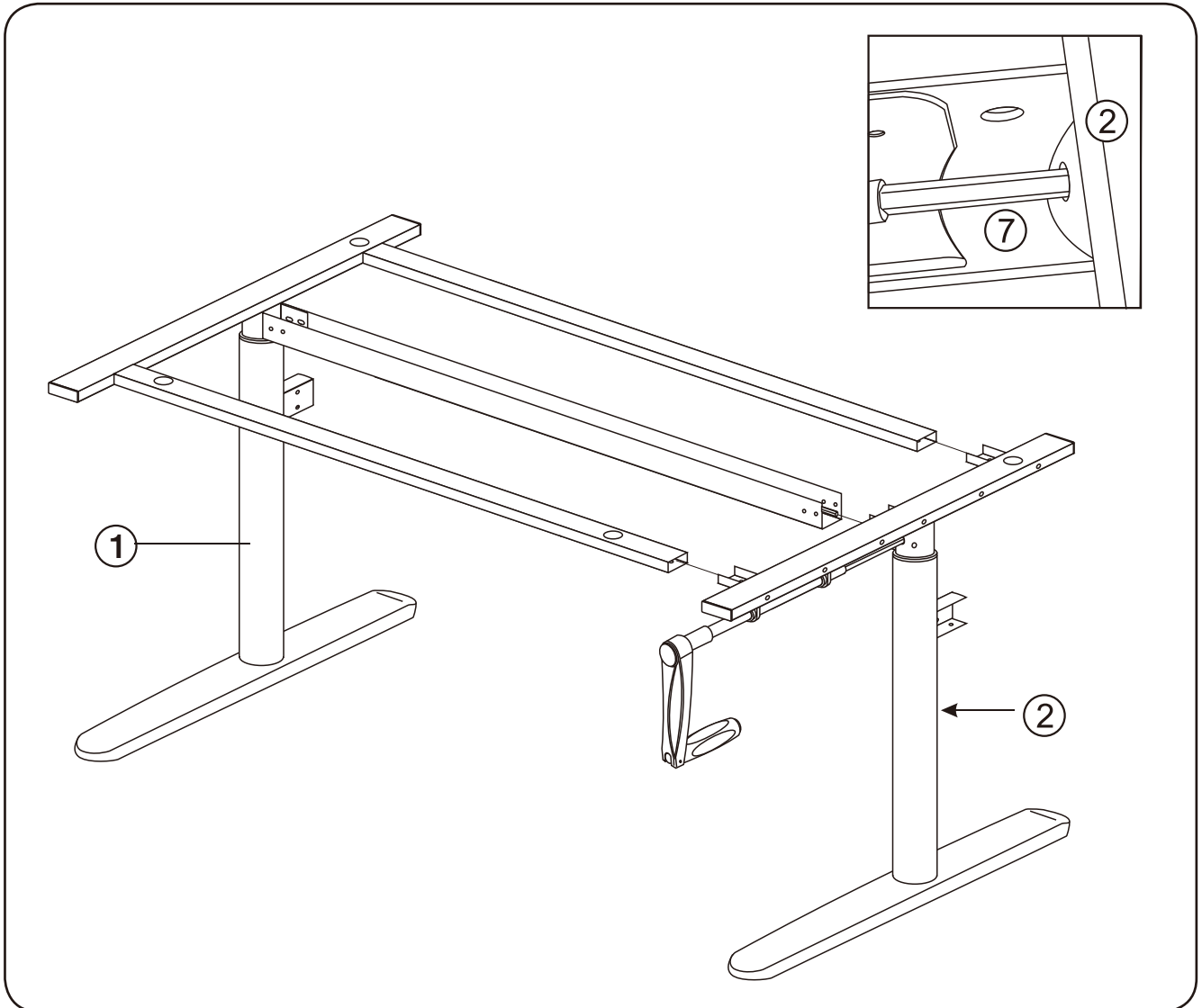

- Pick up the Left Leg (1) and place it upright.
- Pick up the Right Leg (2). Make sure that both legs are level. You can adjust the legs to make them level using the feet on the bottom of the legs. Turn the feet clockwise to raise the desk and counter clockwise to lower it.
- Slide all of the Support Bars (3 & 4) and the Connector (7) onto the Right Leg (2). (Tip: You may need to turn the crank slightly for the Connector (7) to properly slide in.)
- Test to ensure the Connector (7) is in place by turning the crank and making sure that the desk raises evenly on both sides.

Assembly Of The Desk Base - STEP 4

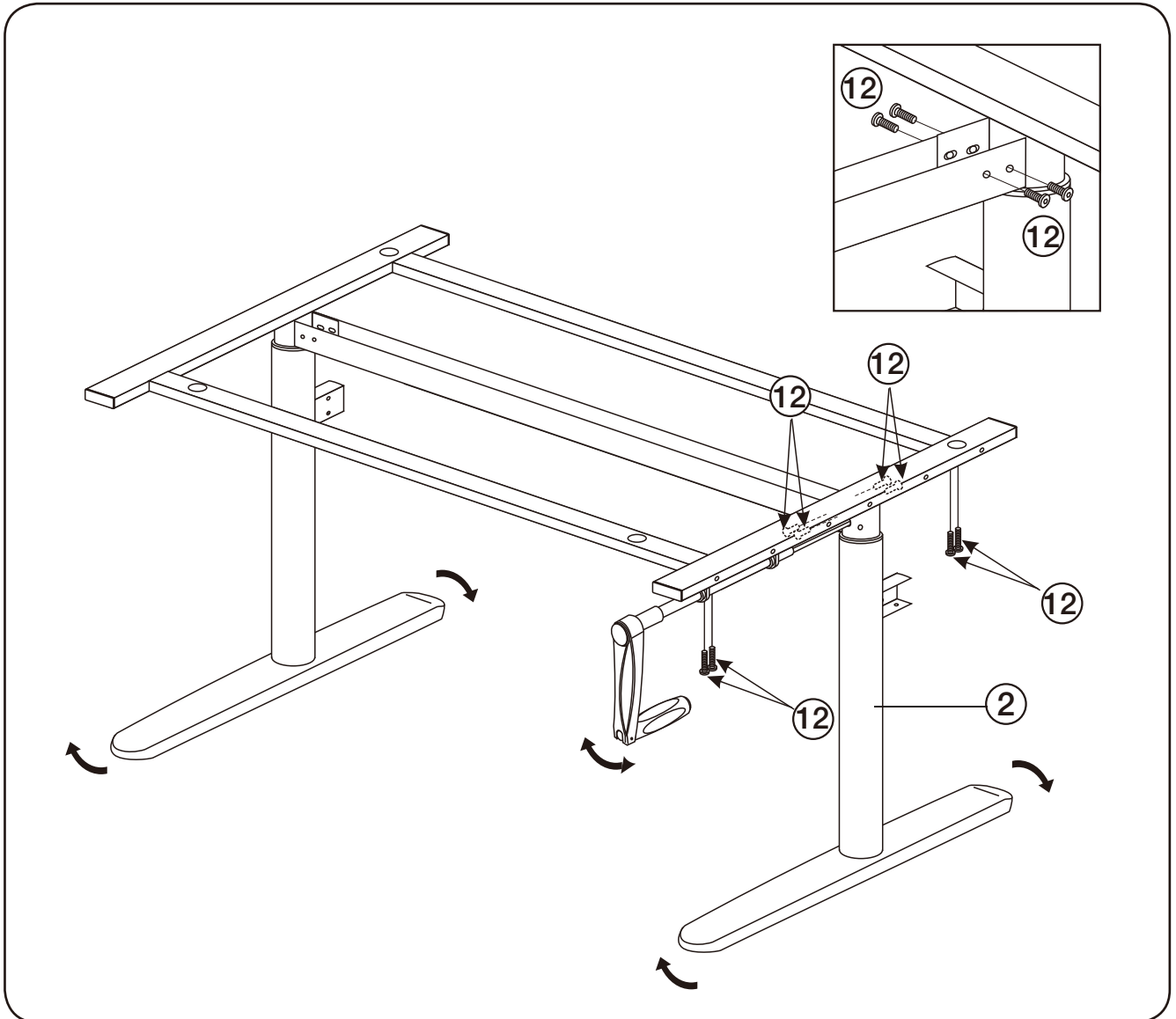

- Push the Legs together.
- Attach the Support Bars to the Right Leg (2) using the Short Allen Bolts (12). Allow the screws to remain slightly loose.

Assembly Of The Desk Base - STEP 5

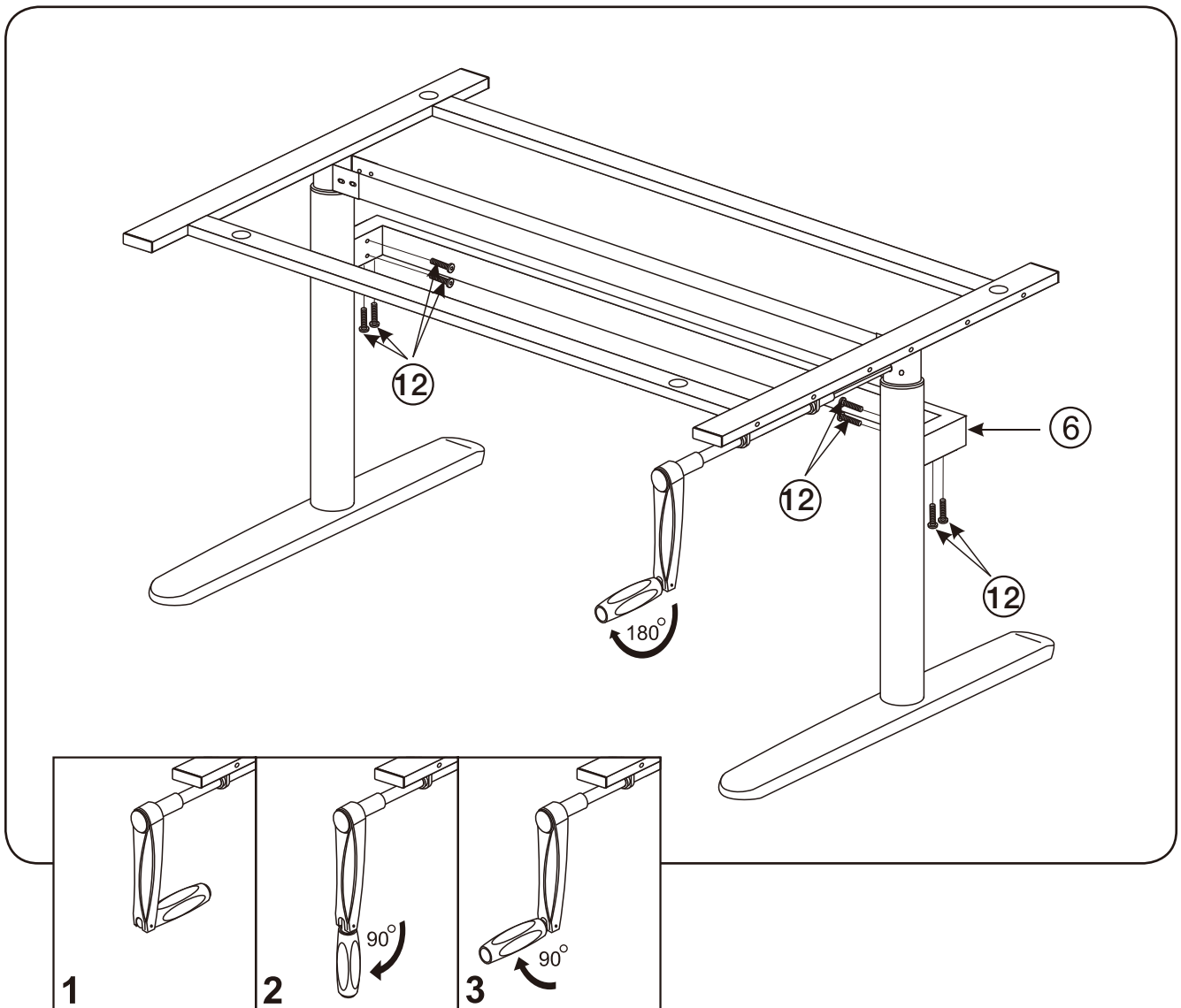

- Place the Rear Bar (6) on the back of the Legs.
- Attach the Rear Bar (6) to the Legs using the Short Allen Bolts (12).
- Tighten all of the screws and bolts everywhere on the base.

Assembly Of The Desk Base - STEP 6

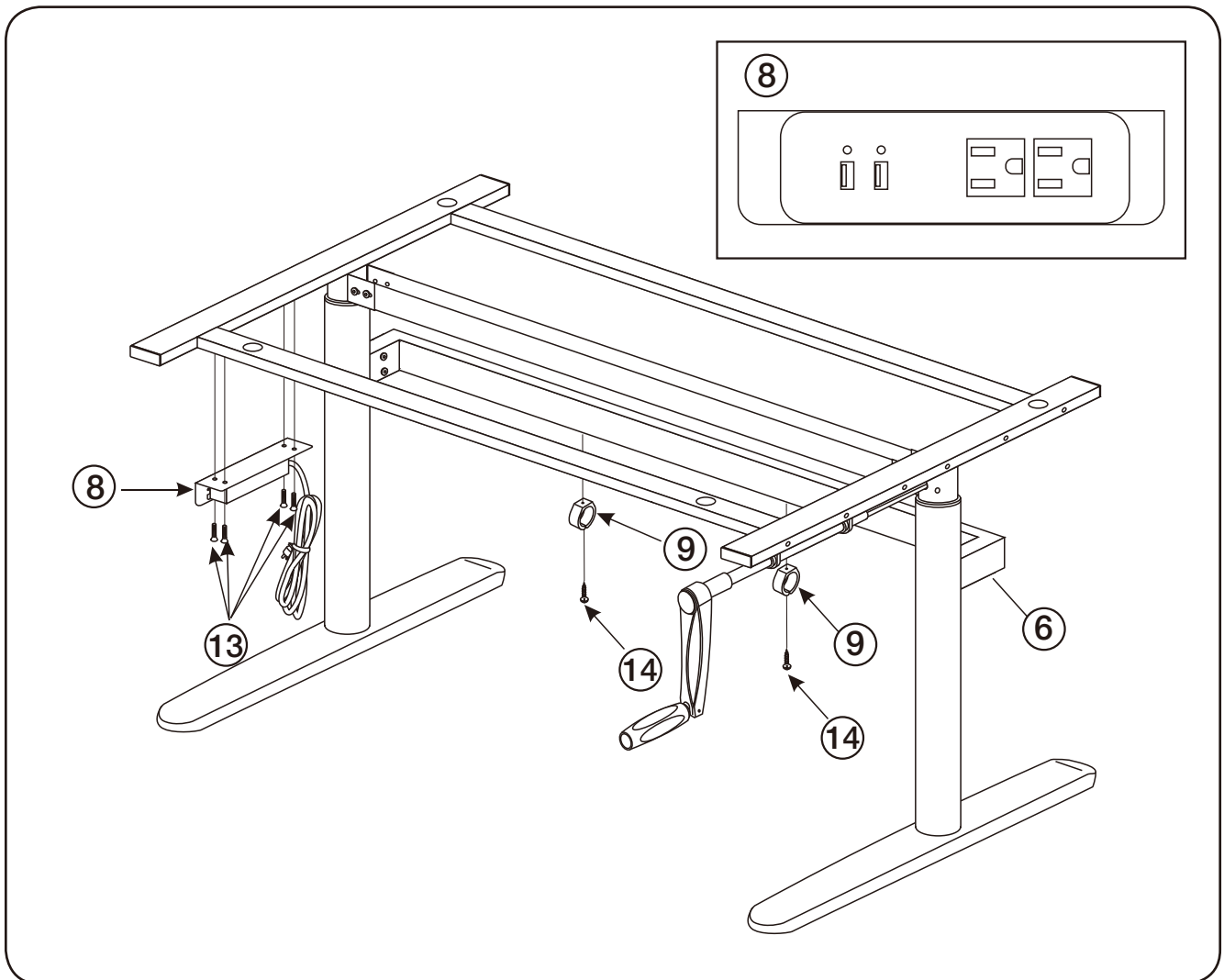

- Attach the Charging Station (8) to the Left Leg using the Phillips Bolts (13).
- The Charging Station (8) contains two electrical receptacles for use with three-prong plugs and two USB charging ports.
- Attach the Cable Collars (9) to the Rear Bar (6) using the Phillips Screws (14).

ATTENTION !

- MAKE SURE ALL BOLTS AND SCREWS HAVE BEEN FULLY TIGHTENED BEFORE USING THE DESK.
- CHECK AND RE-TIGHTEN ALL BOLTS AND SCREWS AT LEAST EVERY 2 MONTHS.

If you purchased the Wood Top, the instructions for attaching it to the desk base are found on pages 13~15.

If you purchased the Glass Top, the instructions for attaching it to the desk base are found on pages 16~19.

If you are attaching your own wood top, you may use the instructions on pages 13~15 as a guide.

You will need to drill holes in your own wood top and to use your own screws and/or bolts.

Make sure that the screws and/or bolts are not so long as to go through the desktop.

Assembly Of The Wood Top - STEP 1

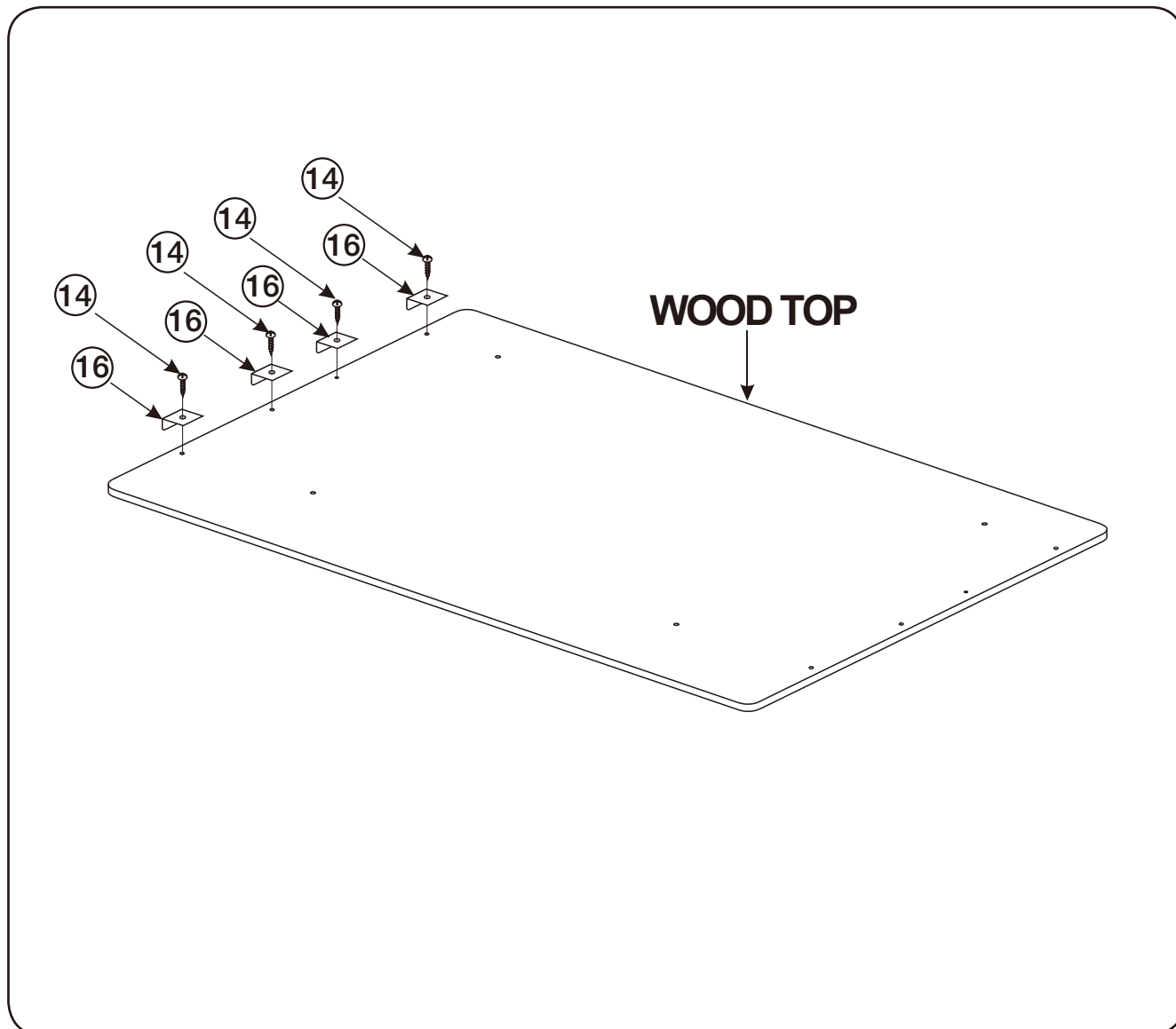

- Attach all Plastic Brackets (16) to the bottom of the Wood Desktop using the Phillips Screws (14).

Assembly Of The Wood Top - STEP 2

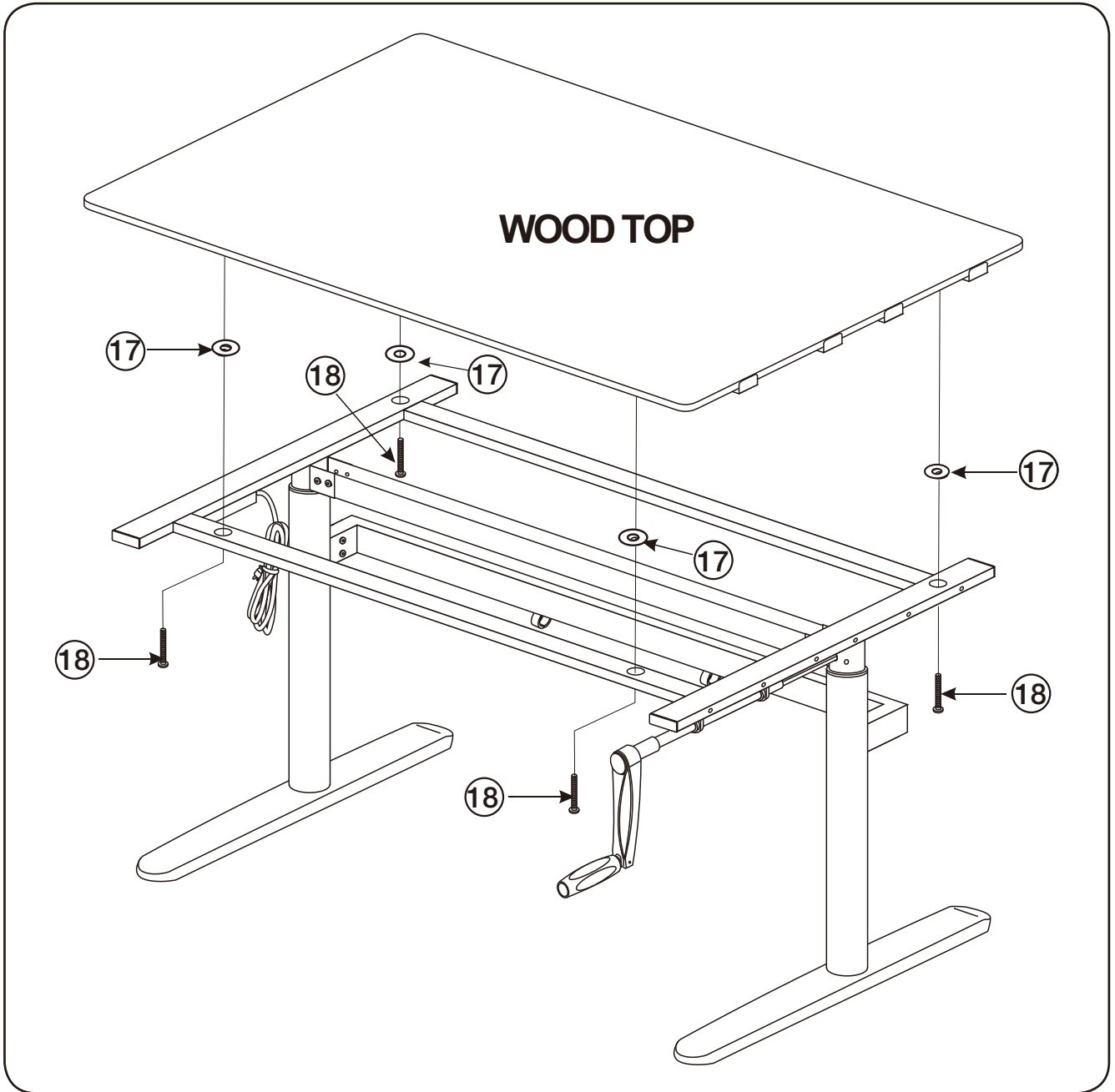

- Attach the Wood Top to the base using the Washers (17) and the Long Allen Bolts (18).

Assembly Of The Wood Top - STEP 3

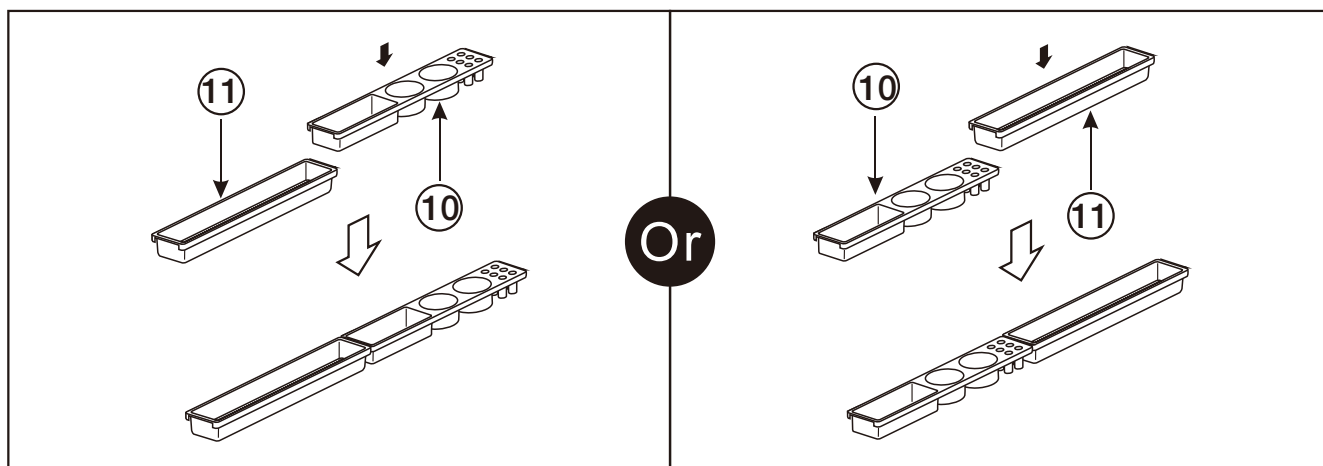
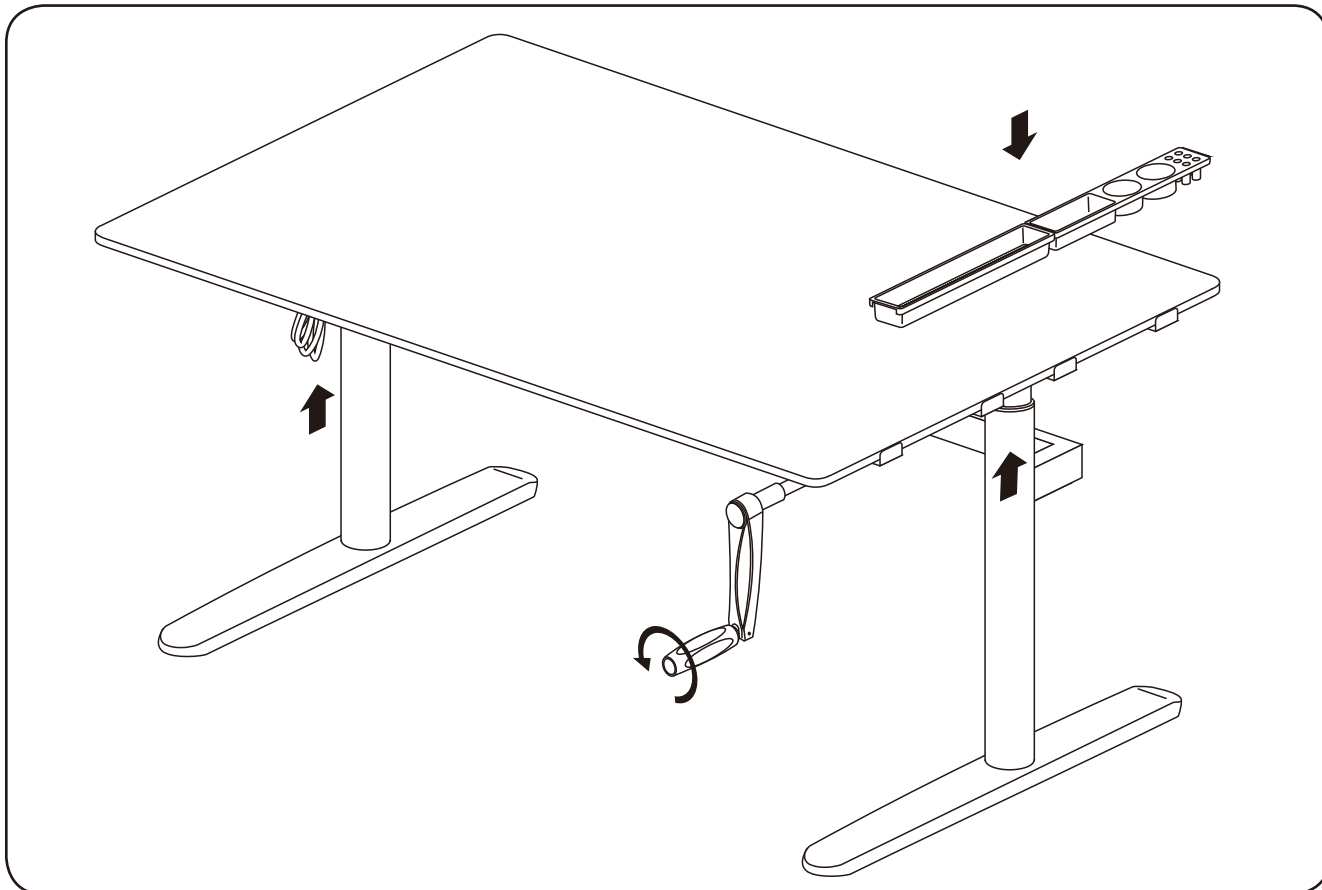

- Attach the Organizer Trays (10 & 11) by sliding them onto the Brackets (16).
- Turn the crank to adjust the height either higher or lower.

ATTENTION !

- MAKE SURE ALL BOLTS AND SCREWS HAVE BEEN FULLY TIGHTENED BEFORE USING THE DESK.
- CHECK AND RE-TIGHTEN ALL BOLTS AND SCREWS AT LEAST EVERY 2 MONTHS.

Assembly Of The Glass Top - STEP 1

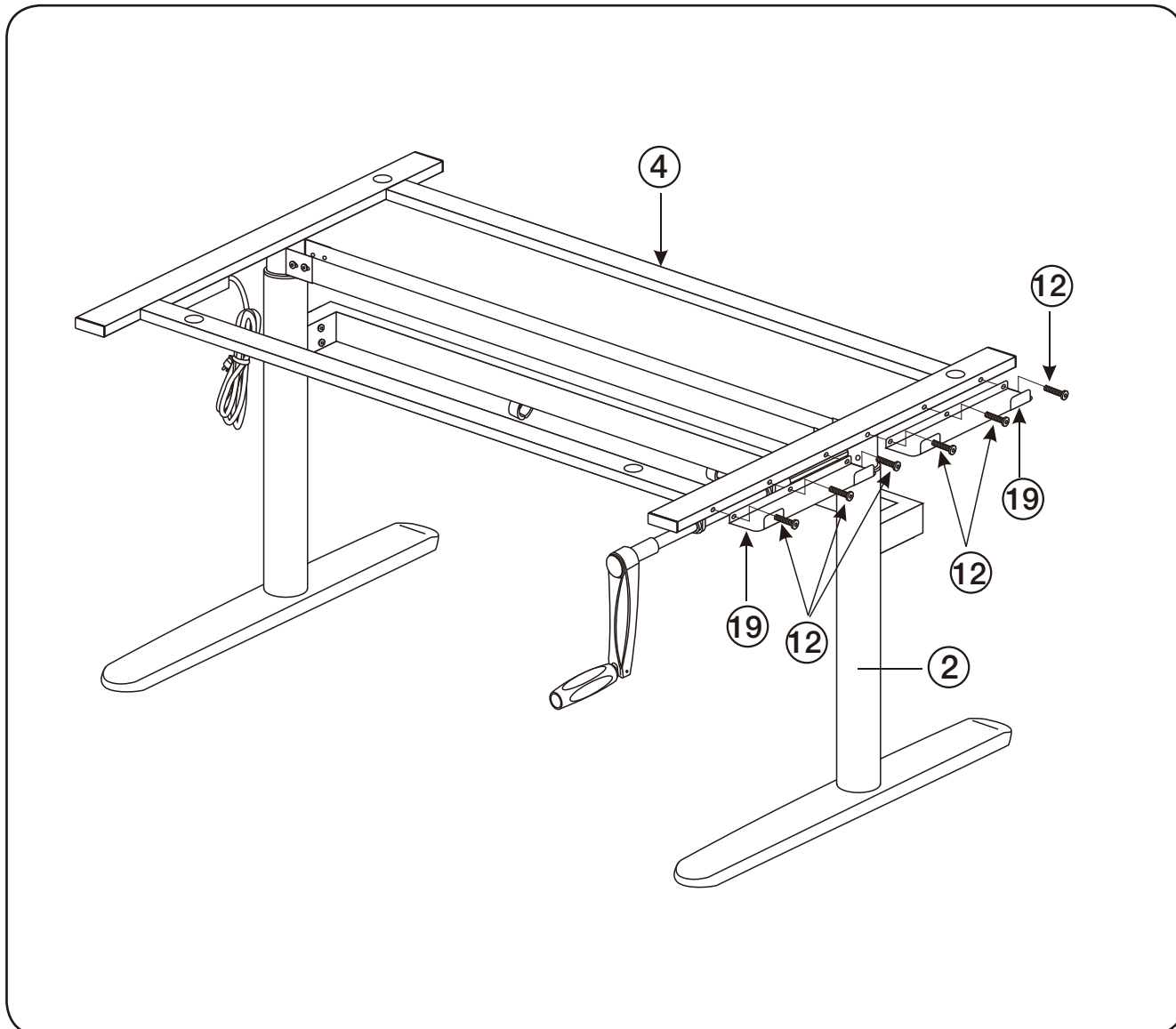

- Attach the Support Trays (19) to the Right Leg (2) using the Short Allen Bolts (12).

Assembly Of The Glass Top - STEP 2

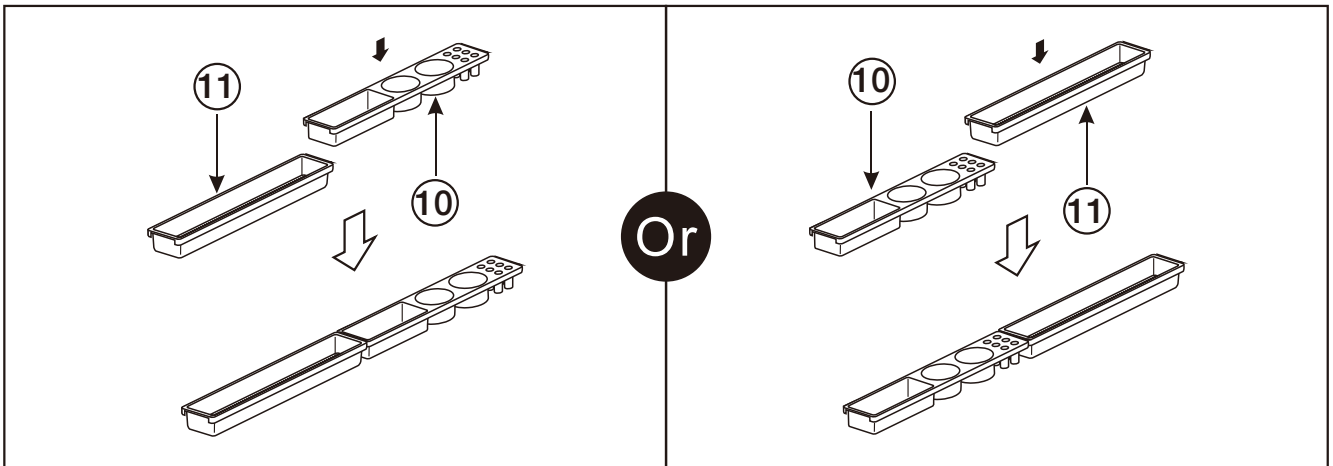
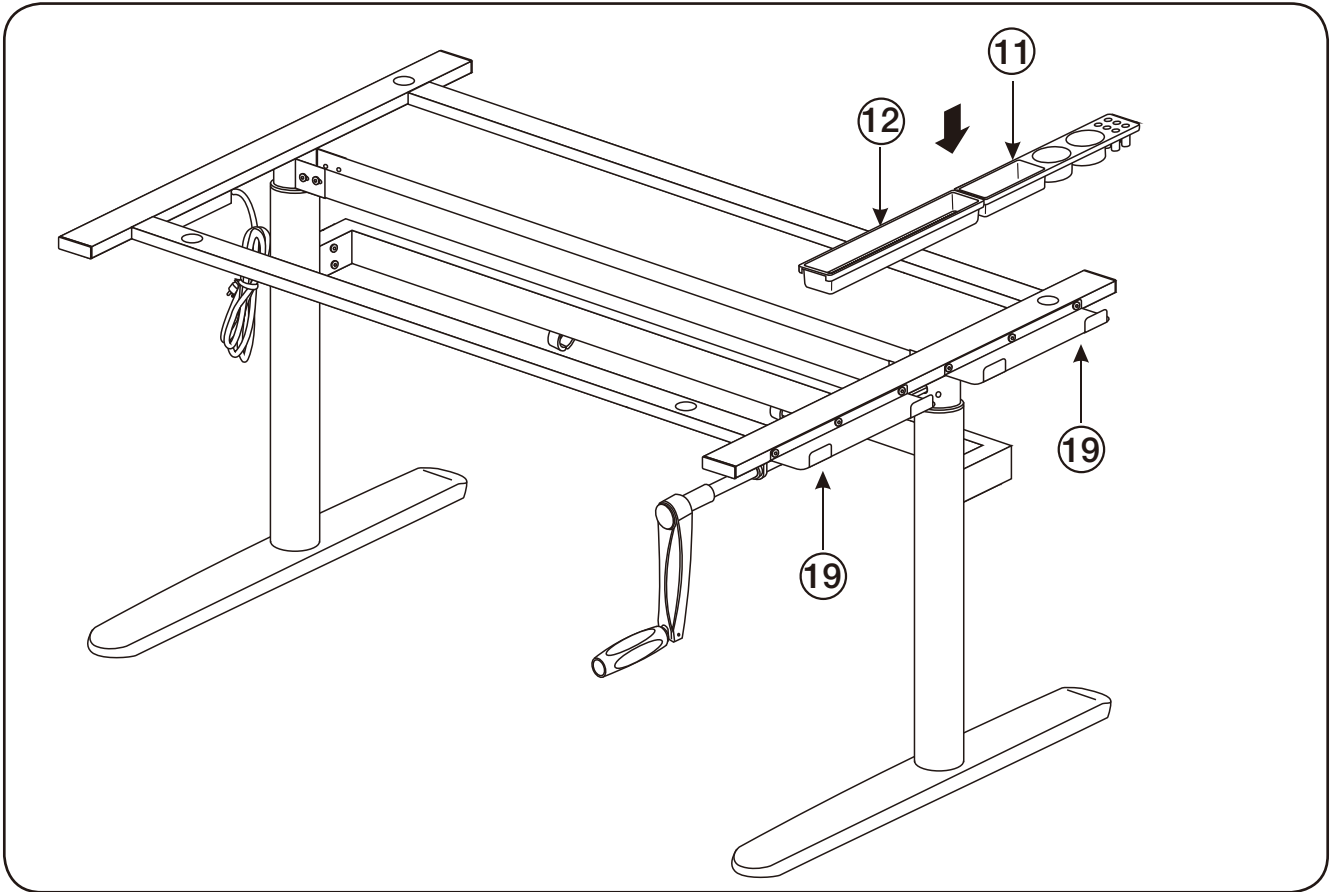

- Attach the Organizer Trays (10 & 11) by sliding them onto the Support Trays (19).

Assembly Of The Glass Top - STEP 3

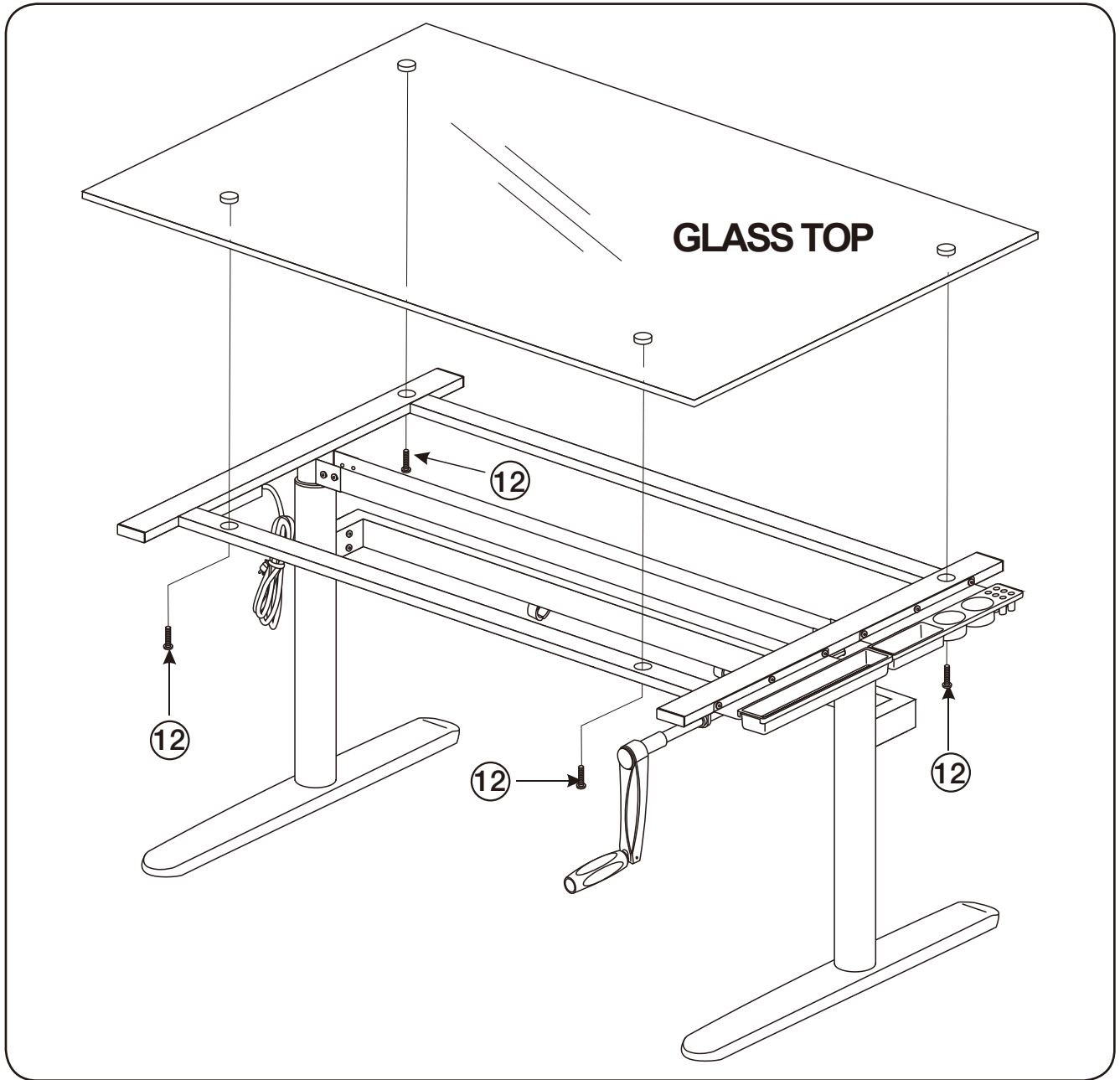

- Attach the Glass Top to the Front Support Bar (3), Left Leg and Right Leg using the Short Allen Bolts (12).

Assembly Of The Glass Top - STEP 4

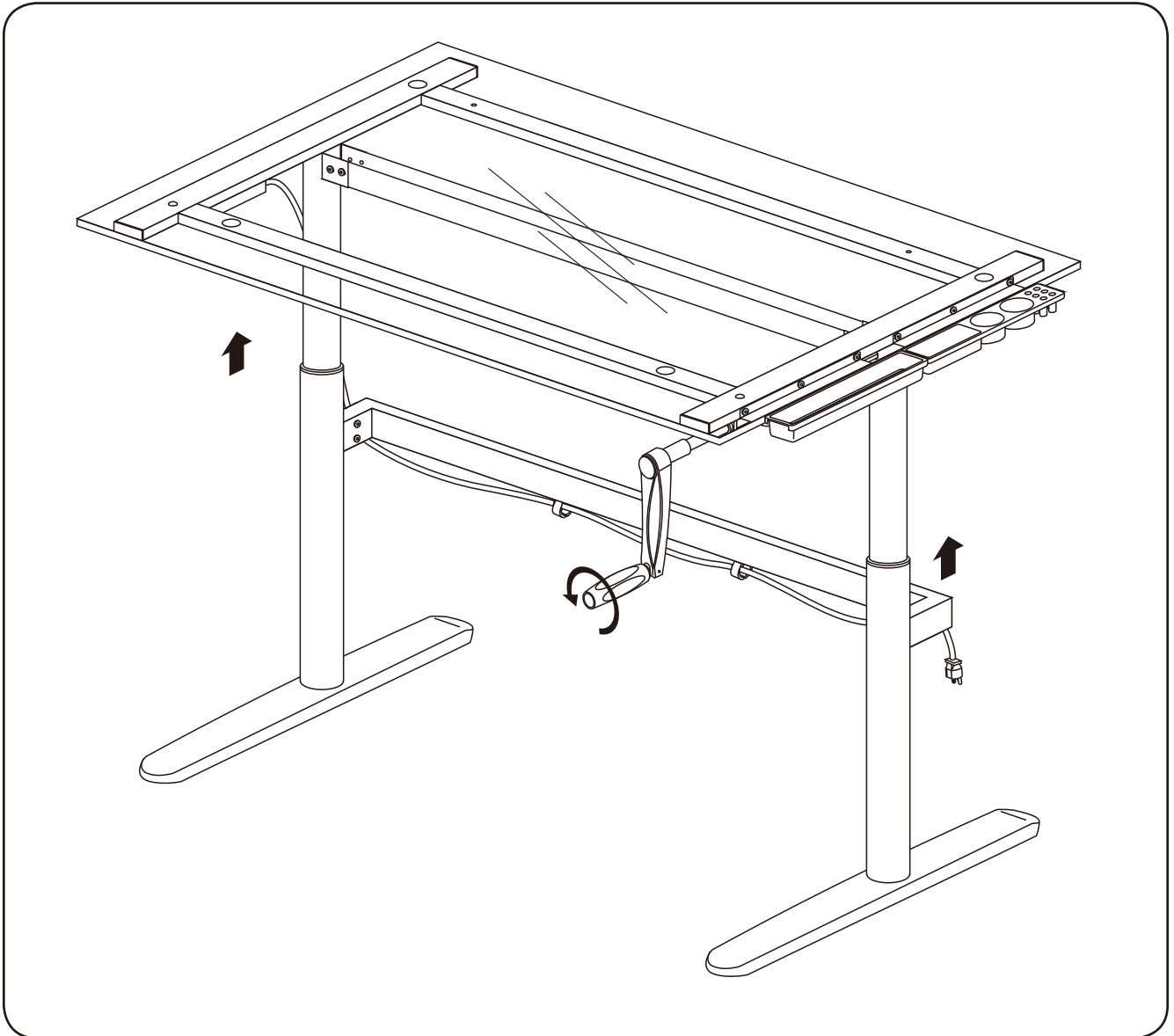

- Turn the crank to adjust the height either higher or lower.

ATTENTION !

- MAKE SURE ALL BOLTS AND SCREWS HAVE BEEN FULLY TIGHTENED BEFORE USING THE DESK.
- CHECK AND RE-TIGHTEN ALL BOLTS AND SCREWS AT LEAST EVERY 2 MONTHS.